



JPF4816 型 PWM 直流风机温控调速器

JPF4826 Type 4-line PWM DC fan speed control terminal by temperature

用户手册 v4.0

User Manual v4.0



成都兢志成电子科技有限公司

Chengdu Jingzhicheng Electronic Technology Co., LTD



版权©2023 成都兢志成电子科技有限公司保留所有权

Copyright © 2023 Chengdu Jingzhi Cheng Electronic Technology Co., Ltd. retains the ownership

所有权信息

未经版权所有者同意，不得将本文档的全部或者部分以纸面或者电子文档的形式重新发布。本文档仅用于辅助用户使用产品，我司不对因该文档中的信息而引起的损失或者错误负责。本文档描述的产品可能会不断地升级完善，我司有权在未通知用户的情况下修改本文档。

Ownership information

All or part of this document shall not be republished in paper or electronic document without the consent of the copyright owner.

This document is only used to assist users with the product, and we are not responsible for the loss or error caused by the information in this document

The products described in this document may be continuously upgraded and improved, and we have the right to modify this document without notifying the users.

版本信息/Version information:

版本号 Version number	主要变更内容 Main change content	日期 date
V1.00	初始版本 The initial version	2017-09
V2.01	细节描述优化 Details description optimization	2021-05
V3.00	增加风扇转速检测、PWM 频率调节相关描述 Add the fan speed detection and PWM frequency adjustment related description	2023-02
V4.00	温控范围扩展至-20-120℃、风机启动/全速温度独立成两个寄存器、风机故障代码支持 03 功能码查询、说明书增加英文注释、其他优化 The temperature control range has been expanded to -20-120 °C, the fan start/full speed temperature has been independently divided into two registers, the fan fault code supports 03 function code Read, English annotations have been added to the manual, and other optimizations have been made	2023-06



1. 功能概述/Function overview

工业级技术方案，采用 ARM 内核单片机作为主控芯片，带温度显示，调速器通过检测到的温度来控制风机转速，温度越高，风机转速越快，温度越低，风机转速越慢，当温度低于启动温度时，风机关停或维持最小转速；支持风机故障检测及报警输出，调速器支持 RS485 串口通信，通过串口协议可以控制风机转速、配置和查询调速器参数及状态，串口指令遵循 modbus-rtu 协议。

Industrial level technical solution, using ARM core microcontroller as the main control chip with temperature display, the governor controls the fan speed based on the detected temperature. The higher the temperature, the faster the fan speed. The lower the temperature, the slower the fan speed. When the temperature is lower than the starting temperature, the fan will stop or maintain the minimum speed; Support fan fault detection and alarm output, The governor supports RS485 serial communication, and through the serial protocol, the fan speed can be controlled, configured, and the governor parameters and status can be queried. The serial command follows the modbus rtu protocol.

2. 技术参数/Technical parameters

1. 工业级方案，采用 ARM 系列单片机作为主控芯片，性能稳定
Industrial-level scheme, using ARM series single-chip microcomputer as the main control chip, with stable performance
2. 宽电压设计，支持 12V/24V/48V 四线 PWM 风机/电机直接接入，最大驱动电流 6A
Wide voltage design, support the direct access of 12V / 24V / 48V four-wire PWM fan / motor, and the maximum drive current of 6A
3. 带 LED 指示，直观指示调速器的工作状态
With LED indication, visually indicate the working state of the governor
4. 电源防反接保护设计，电源接反不会烧坏板子
Power supply anti-reverse protection design
5. 风机启动、全速温度可自由设置，支持最小转速和关停风机两种工作模式
Fan Start and full speed temperature can be set freely, and support two working modes of minimum speed and shutdown fan
6. 支持风机故障检测，自带 OC 信号输出
Support the fan fault detection, with the OC signal output
7. 标准 modbus-Rtu 协议，支持 RS485 串口设置各项参数、查询风机状态、控制风机转速
Standard modbus-Rtu protocol, support RS485 serial port to set various parameters, Read the fan status, and control the fan speed
8. RS485 串口 TVS 防浪涌设计，串口参数默认为 9600bps, 8, N, 1
RS485 serial port TVS surge prevention design, the default serial port parameters are 9600bps, 8, N, 1
9. 100%关停所有的 4 线风机
100% shutdown all 4-line fans



10. PWM 输出幅度 5V, 频率可调
PWM frequency is adjustable, and the amplitude is 5V
11. 支持风机转速检测
Support the fan rotation speed detection
12. 测温范围: -20~120°C
Temperature measurement range: -20~120°C,
13. 测温精度: $\pm 1^\circ\text{C}$
Temperature measurement accuracy: $\pm 1^\circ\text{C}$
14. 工作温度范围: -30~80°C
Operating temperature range: -30~80°C
15. 净重: $\approx 120\text{g}$
Net weight: $\approx 120\text{g}$

3. 产品尺寸/Product size

- 3.1 主板外观尺寸: 70*46*20mm
Motherboard Appearance size: 70*46*20mm

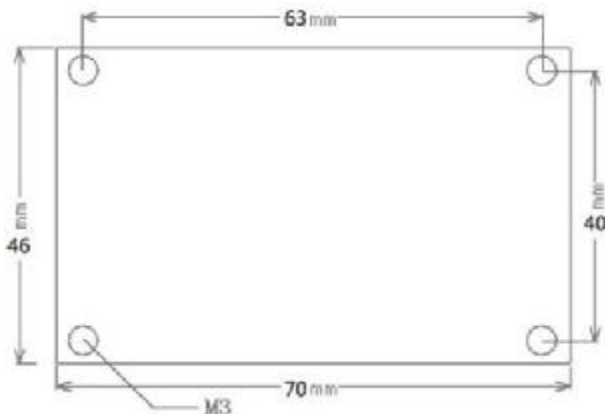

- 3.2, 显示器: 79mm*42mm*26mm, 安装开孔 76mm*40mm
Display: 79mm * 42mm * 26mm, installation hole 76mm * 40mm



4. 接口说明/Interface specification

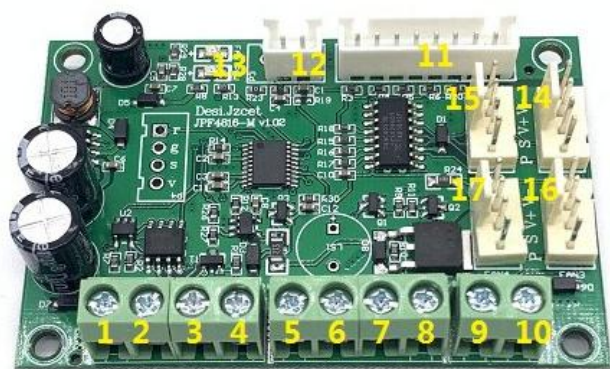

1号端子: 调速器供电电源+极接口 / No.1: power supply +,

2号端子: 调速器供电电源-极接口 / No.2: power supply -,

3号端子: RS485 串口 A / D+ / No.3: RS485 serial port A / D +,

4号端子: RS485 串口 B / D- / No.4: RS485 serial port B / D -,

5号接风扇电源- / No.5 to fan power supply -,

6号接风扇电源+ / No.6 to fan power supply +,

7号接风扇转速信号 / No.7 to fan speed signal (FG),

8号接风扇 PWM 控制线 / No.8 to fan PWM control line,

*5-8号端子主要是为了方便没有插头的风扇接线, 和14号接口的4位插针是直通的)

* Port 5-8 connects to port 14 directly

9号端子: 风机故障信号 OC 输出口 (NPN 输出接口)

No.9: Fan fault signal OC output port (NPN output interface)

10号端子: GND / No.10: GND

11号接口: 显示板接口 / Interface 11: Display board interface

12号接口: 温度探头接口 / Interface 12: Temperature probe interface

13号位置: LED 指示灯, POW 为整机电源指示灯, PWM 为风机控制指示灯

Position 13: LED indicator light, POW is the overall power indicator light, PWM is the fan control indicator light

14-17号接口: 第1-4路风机接口, 标准KF2510-4P座子, 线序: fan-、fan+、FG、PWM

No.14-17 interface: the 1-4 road fan interface, standard KF2510-4P seat,

line order: fan-, fan +, FG, PWM



4.1 全功能接线示意图 / wiring diagram

(实际使用时，部分用不到的功能，直接忽略其接线即可)

(in actual use, part of the unused functions, the wiring can be directly ignored)

*不能带电插拔风机，否则可能会损坏调速器

* Unable to plug and unplug the fan while working

*直流电源的电压必须和所接风扇的额定电压一致，且输出电流必须大于风扇电流的总和

* The voltage of the DC power supply must be the same with the rated voltage of the connected fan, and the output current must be greater than the sum of the fan current

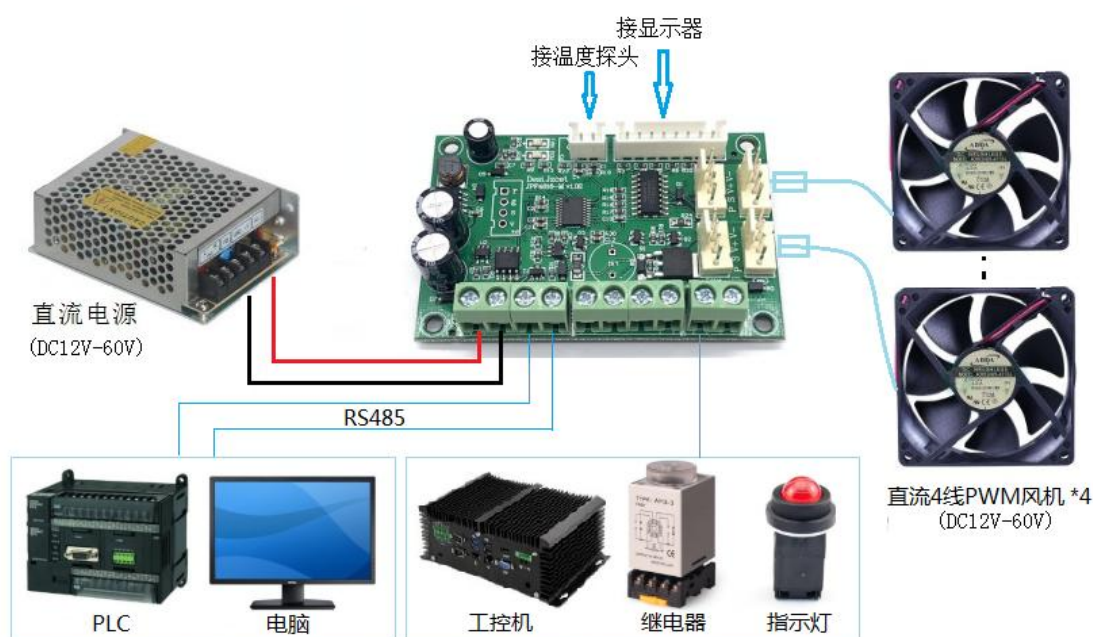

5. 基础功能使用说明/Come into use

5.1 按接口说明连接好接线

Connect the wiring according to the interface Commands

5.2 供电正常后，主板上的 POW 灯会亮起，此时调速器开始检测当前温度，并根据当前设置的温度区间来调节风机的转速，以调速器出厂默认的温度区间为例，调速器出厂默认的温度区间为 L=30℃、H=50℃，当检测到当前温度大于等于 30℃时，调速器按线性比例调节风扇的转速，温度升高，风扇转速也会加快，当温度≥50℃时，风机变为全速。当温度降低到≤27℃（L-3）时，调速器使风扇处于最小转速/或关停风机。

After the power supply is normal, the POW light on the motherboard lights up, the governor starts to detect the current temperature, and adjust the speed of the fan according to the current temperature interval. Take the default temperature interval of the governor as an example, the default temperature interval of the governor is L=30℃, H=50℃. When the current temperature is greater than or equal to 30℃, the governor adjusts the fan speed in linear proportion, and the fan speed will accelerate. When the temperature is 50℃, the fan changes to full speed. When the temperature is lowered to ≤27℃ (L-3), the governor makes the fan at the minimum speed / or stop the fan.

风机转速&温度关系示意图:

Schematic diagram of the fan rotation speed & temperature relationship:

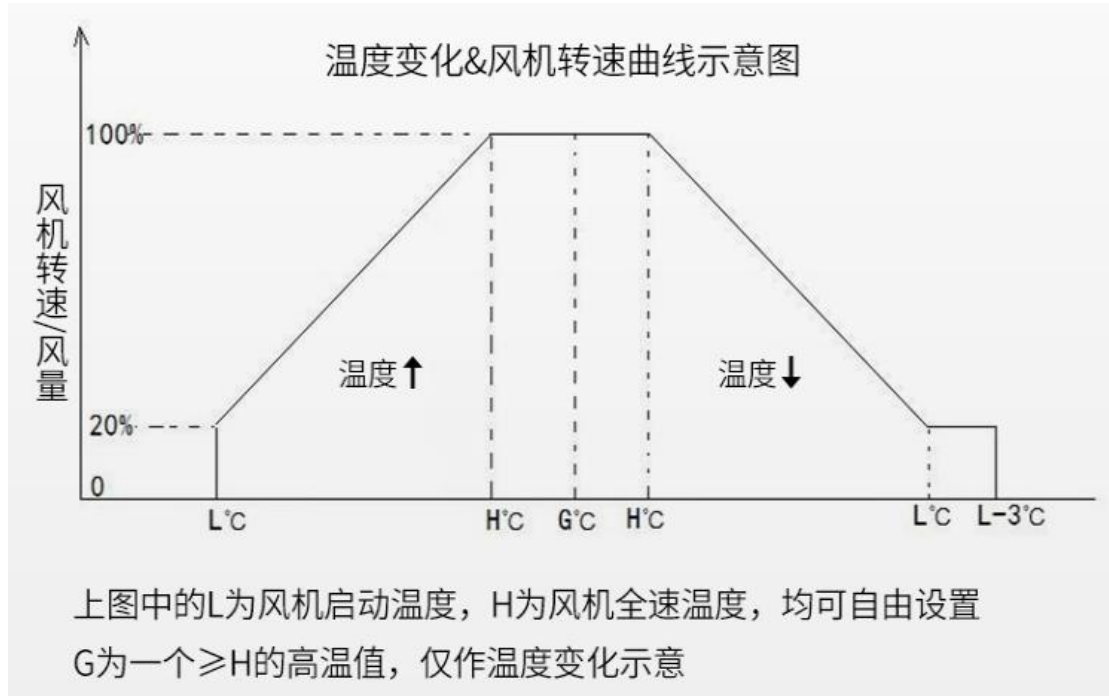

In the figure above, L is the starting temperature of the fan, and H is the temperature of the fan at full speed, which can be set freely.

G is for reference only,



6. 数码面板操作说明 / Panel operation Commands:

数码面板实时显示当前温度，带 4 个按键，通过按键可以设置调速器的所有参数
待机状态下，按 MODE 键可进入配置/切换参数项，配置时按↓键可以调整数值，OK 键确认
The digital panel displays the current temperature in real time, with four keys,
through which all the parameters of the governor can be set In standby state, press
MODE key to enter the configuration / switch parameter items, and press ↓ key to
adjust the value, and OK key to confirm

*设置参数时，每设置一项参数（改变了参数值），都必须按一次 OK 键确认，再设下一项。
* When setting the parameters, for each parameter set (the parameter value is
changed), you must press the OK key once to confirm, and then set the next item.

参数项/Parameter item

数显代号 Number of code	参数释义 Parameter definition	参数说明 parameter declaration
Lxx	风机启动温度 Start temperature of fan	设置风机的启动（下限）温度值 设置范围：-20~120℃ Set the start temperature value of the fan Setting range: -20~120℃
Hxx	风机全速温度 Full speed temperature of fan	设置风机的全速（上限）温度值 设置范围：-20~120℃，H 的值必须大于 L 的值 Set the full speed temperature value of the fan Set the range: -20~120℃, the value of H must be greater than the value of L
Axx	MODBUS 地址 MODBUS address	设置调速器的 485 串口 MODBUS 协议的地址 设置范围：1~254 Set the address of the 485 serial port MODBUS protocol for the governor Setting range: 1~254
Pxx	工作模式 work pattern	设置调速器的工作模式 当温度小于设置的启动温度-3℃时，用此参数设置调速器是 控制风机关闭还是维持风机处于最小（20%）的转速） 设置范围： 01 表示维持最小转速，00 表示关闭风机 Set up the working mode of the governor When the temperature is less than the set start temperature-3℃, use this parameter to set the governor to control the fan off or maintain the fan at the minimum (20%) speed) Setting range: 01 means maintaining the minimum rotation speed, and 00 means turning off the fan



Fxx	风机数量 fan number	<p>设置接入调速器的风机数量</p> <p>此项参数的值必须和实际接入的风机数量一致，且在接入风机时，必须按 FAN1~FAN4 的顺序依次接入风机，如果设置是 01，那么实际接风扇时，风机必须接在 fan1 口，如果设置是 02，那么实际接风扇时，2 个风机必须接在 fan1、fan2，以此类推，如果未按此要求接入将导致风机故障检测功能出错</p> <p>设置范围：0~4（设置为 0 时表示不启用风机故障检测功能）</p> <p>Set the number of fans connected to the governor</p> <p>The value of this parameter must be consistent with the actual number of fans, and the fan must be connected in the order of FAN 1 to FAN 4. If the setting is 01, the fan must be connected to fan1 and 02, the fan1, fan2, and so on. If the fan is not required, the fan fault detection function is wrong</p> <p>Setting range: 0~4 (when set to 0, the fan fault detection function is not enabled)</p>
-----	--------------------	---

*以设置风机的启动、全速温度为例

* Take setting the start and full speed temperature of the fan as an example

待机状态下，面板显示当前的温度值，按 1 下 MODE 键，数码管显示 Lxx，L 代表启动温度，xx 表示当前设置的温度值，

按上下键可以调整参数值，调整完成后，按 ok 键确认，回到待机界面

In the standby state, the panel shows the current temperature value, press 1 MODE key, the digital tube displays Lxx, L represents the start temperature, xx represents the currently set temperature value, Press the upper and lower keys to adjust the parameter value. After the adjustment is completed, press the ok key to confirm and return to the standby interface

待机状态下，按 2 下 MODE 键，数码管显示 Hxx，H 代表全速温度，xx 表示当前设置的温度值，按上下键可以调整参数值，调整完成后，按 ok 键确认

In standby state, press MODE key for 2, the digital tube shows Hxx, H represents the full speed temperature, xx represents the current set temperature value, press the upper and lower key to adjust the parameter value, after the adjustment is completed, press OK key to confirm

设置完成，调速器将根据新设置的温度参数来自动控制风机的转速。

其他参数的设置与上面步骤类似。

When the setting is complete, the governor will automatically control the speed of the fan according to the newly set temperature parameters. The other parameters were set similarly to the above steps.



7. 风机故障信息输出 NPN (OC 口) 使用说明/About Fan fault signal

此功能必须要配合“风机数量”参数以及风机必须按要求接线才能正常使用

This function must be compatible with the "Number of Fans" parameter and the fans must be wired as required to function properly

示意图如下/The schematic diagram is as follows:

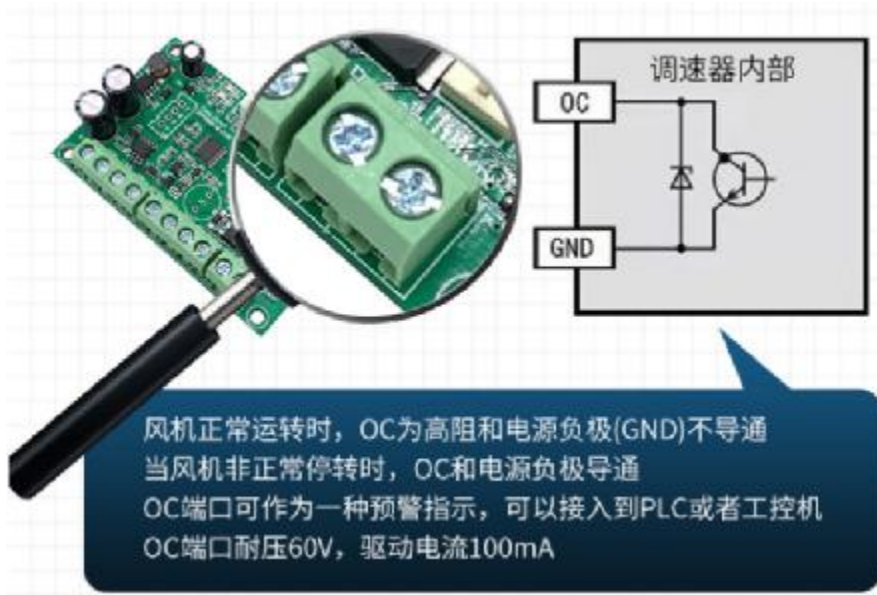

用法 1: OC 口驱动继电器 / Usage 1: OC port drive relay

调速器的 OC 端口可以直接驱动继电器，接线如下图，通过控制继电器，可以实现风机故障时，去控制报警装置或开启其他大功率散热设备

The OC port of the governor can directly drive the relay, as shown in the following diagram. By controlling the relay, it is possible to control the alarm device or turn on other high-power heat dissipation devices in case of fan failure

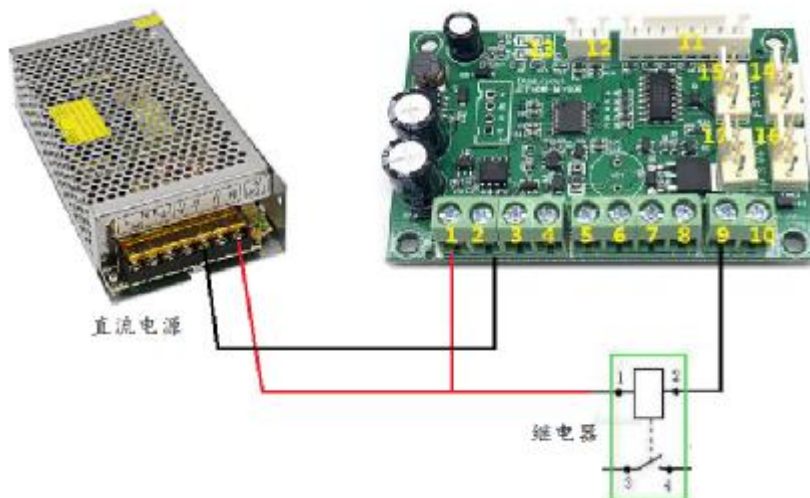

用法 2: 驱动指示灯 / Usage 2: Drive indicator light

如下图所示, OC 端口来驱动一个小的指示灯, 当风机出现故障时, 指示灯会亮起,
As shown in the following figure, the OC port drives a small indicator light, which will light up when the fan malfunctions,

驱动指示灯时, 需注意以下事项:

the following precautions should be taken:

1. 指示灯的最大电流不能超过 100mA /
The maximum current cannot exceed 100mA
2. 如果是普通的 LED 灯珠, 必须在灯的回路上加限流电阻
If it is a regular LED bead, a current limiting resistor must be added to the circuit of the lamp
3. 如果是成品的指示灯, 灯的内部可能已集成了限流电阻, 则不需再加限流电阻
If it is a finished indicator light, the internal part of the light may have integrated a current limiting resistor, so there is no need to add a current limiting resistor

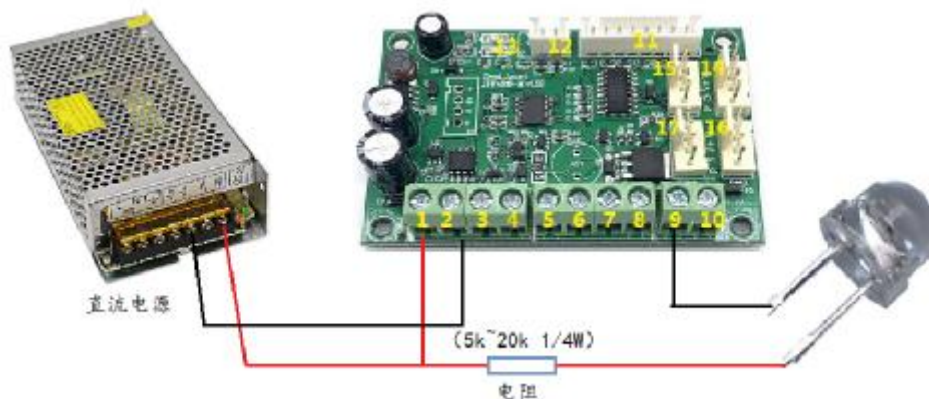

用法 3: 接入到 PLC 或工控机 / Connect to PLC or industrial computer

调速器的 OC 端口为 NPN 信号输出, 可以接入到工控机或 PLC 的开关量采集口, 用此可以检测风机是否出现故障

The OC port can be connected to industrial computer or PLC

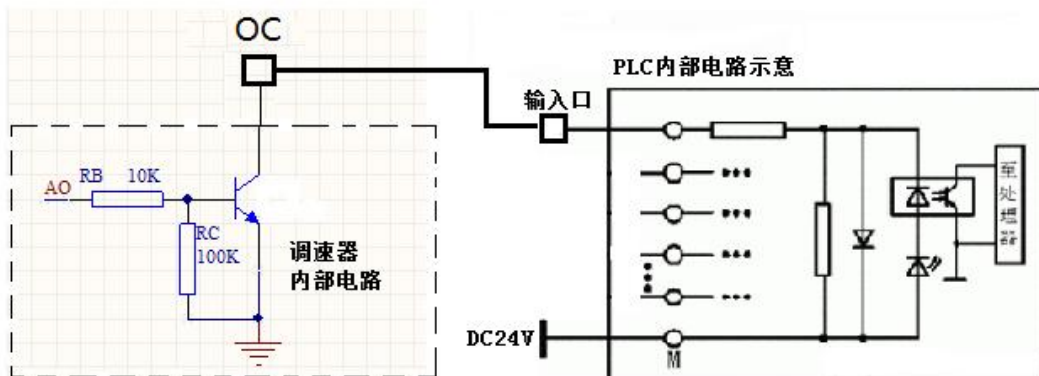



8. RS485 串口通信协议说明/ Communication protocol

8.1 本协议遵守 MODBUS-RTU 通信协议, 参照 MODBUS 协议中的子集 RTU 方式.

调速器作为从机, 只能被动接收主机的命令, 不主动上报数据.

This protocol complies with the MODBUS-RTU communication protocol, referring to the subset RTU mode in the MODBUS protocol. As a slave, the governor can only passively receive commands from the host and does not actively report data.

协议格式如下 (hex):

*主机读取

MODBUS 地址	功能码	寄存器地址	寄存器数量	CRC16 校验
1byte	0x03	2byte	2byte	2byte

控制器应答读取

MODBUS 地址	功能码	数据值的字节数	数据值	CRC16 校验
1byte	0x03	1byte	<u>nbyte</u>	2byte

*主机写 (配置参数), 一次只可以写单个寄存器的数据

MODBUS 地址	功能码	寄存器地址	数据值	CRC16 校验
1byte	0x06	2byte	2byte	2byte

控制器应答写

MODBUS 地址	功能码	寄存器地址	数据值	CRC16 校验
1byte	0x06	2byte	2byte	2byte

8.2. 串口参数/Serial port parameters

波特率 9600, 无校验, 8 位数据, 1 位停止位

Porter rate 9600, no check, 8 bit data, 1 bit stop bit

*寄存器地址如下表 / Register address is listed below:

寄存器地址 Register address	说明 explain	允许操作 Allow operation	功能码 Function code
0x0000	当前温度值, 正偏移 40, 实际温度值=解析值-40. Current temperature, positive offset of 40, value = analytical value of - 40.	只读 read only	0x03
0x0001	风机状态, 数据内容换算成 2 进制后, 最低位代表 fan1, 次低位代表 fan2……; 详见后页说明, Fan status, Convert data content to binary, the lowest level represents fan1, and the second low level represents fan2...; See the following page for details.	只读 read only	0x03/0x02



0x0002	<p>MODBUS-485 地址, 取值范围: 0x0001-0x00FE, *支持 FFFF 广播地址, MODBUS-485 Address, Value range: 0x0001-0x00FE, *Support for FFFF broadcast addresses.</p>	<p>读/写 Read/ write</p>	0x03/0x06
0x0003	<p>串口强制控制风机转速, 风机转速值(百分比)完全受控于串口,此状态下温控功能会临时失效,断电重启或写数据值为 0xFFFF 时调速器会恢复到温控, 取值范围: 0x0000-0x0064、0xFFFF, Serial port forced control of the fan speed, The fan speed value (percentage) is completely controlled by the serial port. In this state, the temperature control function will temporarily fail. When the power is off to restart or the governor will resume the data value to 0xFFFF, Value range: 0x0000- 0x0064、0xFFFF.</p>	<p>读/写 Read/ write</p>	0x03/0x06
0x0004	<p>风机启动、全速温度, 高位字节为启动温度,低位字节为全速温度, 取值范围: 0x1415-0xA09F, *正偏移 40, 设置值=数据值-40, Fan start-up、full-speed temperature, High byte is starting temperature, Low byte is full speed temperature, Value range: 0x1415-0xA09F, * Positive offset 40, set value = data value-40.</p>	<p>读/写 Read/ write</p>	0x03/0x06
0x0005	<p>调速器的工作模式, 0x0001=最小转速模式, 0x0000=关停模式, Operating mode of the governor, 0x0001= fan minimum speed mode, 0x0000= fan off mode.</p>	<p>读/写 Read/ write</p>	0x03/0x06
0x0006	<p>风机数量, 取值范围: 0x0001-0x0004 Number of fans, the value range: 0x0001-0x0004.</p>	<p>读/写 Read/ write</p>	0x03/0x06



0x0007~000A	<p>4 个风机的实时转速 (RPM), Fan1 的转速对应 0x0007 的值... *读取到的转速值 (RPM) 是由公式 $60*N/2$ 计算而来: N 是风扇每秒钟产生的脉冲数量, /2 表示风扇转 1 圈会产生 2 个脉冲, 此公式适合市面上绝大多数的风扇, 极少部分特殊风扇的转速需要根据风扇资料/特性自行二次计算 speed of 4 fans (RPM), The speed of Fan1 corresponds to the value of 0x0007... * The speed value (RPM) is calculated from formula $60 * N / 2$: N is the number of pulses generated by the fan per second, and /2 means that the fan turning 1 will produce 2 pulses. This formula is suitable for the vast majority of fans on the market, and the speed of a few special fans needs to be calculated twice according to the data / characteristics of the fan</p>	只读 read only	0x03
0x000B	<p>PWM 输出频率选择, 取值范围: 0x0000~0x0005, 默认为 0005, 如非必要, 此参数应保持默认, 不要修改, 0=500Hz, 1=1KHz, 2=2K, 3=5K, 4=10K, 5=25K. The PWM frequency selection, Value range: 0x0000~0x0005, 0=500Hz, 1=1KHz, 2=2K, 3=5K, 4=10K, 5=25K, *Default to 0005 If not necessary, not be modified.</p>	读/写 Read/ write	0x03/0x06
0x000C	<p>风机启动温度, 取值范围: 0x0014~0x00A0, *正偏移 40, 设置值=数据值-40, Fan starting temperature, Value range: 0x0014~0x00A0, *Positive offset of 40, set value=data value - 40.</p>	读/写 Read/ write	0x03/0x06
0x000D	<p>风机全速温度, 取值范围: 0x0014~0x00A0 *正偏移 40, 设置值=数据值-40 Fan full speed temperature, Value range: 0x0014~0x00A0, *Positive offset of 40, set value=data value - 40.</p>	读/写 Read/ write	0x03/0x06



0x000E	风机故障代码, 数据内容换算成 2 进制后, 最低位代表 fan1, 次低位代表 fan2……, 详见后页说明. Fan fault codes, After converting the data content to binary, the lowest bit represents fan1, and the second lowest bit represents fan2, Please refer to the Commands on the following page for details.	只读 read only	0x03
0x0020	复位重启控制, 取值范围: 0x00AA, *向 0020 寄存器写 00AA 可使调速器复位重启, Restart control, Value range: 0x00AA, Writing 00AA to the 0x0020 register can reset the governor.	只写 write only	0x06

9. RS485 串口协议使用实例/ Use example (Hex)

9.1 查询当前温度 (03 功能码, 寄存器地址 0000)

Read the current temperature (03 function code, register address 0000)

指令格式: 调速器地址 03 00 00 00 01 CRC16

Command format: governor address 03 00 00 00 01 CRC16

调速器返回: 调速器地址 03 02 00 xx CRC16

Governor return: governor address 03 02 00 xx CRC16

xx 为温度数据内容, HEX 格式, 需要换算成十进制,

实际的温度 (°C) = 换算出的十进制值 - 40

xx is temperature data content, HEX format, needs to be converted to decimal,

Actual temperature (°C) = the converted decimal value of -40

以 modbus 地址 01、当前温度为 31°C 为例

Take the modbus address 01, the current temperature is 31°C

主机发送: 01 03 00 00 00 01 84 0A

Host sent: 01 03 00 00 00 01 84 0A

调速器应答: 01 03 02 00 47 F8 76 (0x0047 换成 10 进制=71, 71-40=31°C)

Governor response: 01 03 02 00 47 F8 76 (0x0047 to 10 r =71, 71-40=31°C)



9.2 查询当前风机状态 (03 功能码, 寄存器地址 0001)

Read the current fan status (03 function code, register address 0001)

指令格式: 调速器地址 03 00 01 00 01 CRC16

Command format: governor address 03 00 01 00 01 CRC16

调速器返回: 调速器地址 03 02 00 0x CRC16

Governor return: governor address 03 02 00 0x CRC16

000x 为数据内容, HEX 格式, 需要换算成二进制, 低 4 位就对应 4 个风扇, 从右往左, 最右位对应 1 号风扇, 第 4 位对应 4 号风扇; 0 表示风扇停止, 1 表示风扇运转

000x is the data content, HEX format, which needs to be converted to binary, low 4 bits correspond to 4 fans, from right to left, the most right bit corresponds to fan 1 fan, position 4 corresponds to fan 4; 0 means the fan stops and 1 means the fan runs

以 modbus 地址 01、1 号风机运转, 234 号风机停转

Run with modbus address 01, no. 1 fan, no. 234 fan stop turn

主机发送: 01 03 00 01 00 01 D5 CA

调速器应答: 01 03 02 00 01 79 84 (00 换成 2 进制=0000 0001),

Host Send: 01 03 00 01 00 01 D5 CA

Governor response: 01 03 02 00 01 79 84 (00 changed to 2 rrr =0000 0001)

9.3 设置风机的启动、全速温度 (06 功能码, 寄存器地址 0004)

Set the start and full speed temperature of the fan (06 function code, register address 0004)

指令格式: 调速器地址 06 00 04 LL HH CRC16

Command format: governor address 06 00 04 LL HH CRC16

调速器返回: 调速器地址 06 00 04 LL HH CRC16

Governor return: governor address 06 00 04 LL HH CRC16

LL 换成十进制 -40, 就表示风机的启动温度值

LL is replaced by Decimal -40, which indicates the starting temperature value of the fan,

HH 换成十进制 -40, 就表示风机的全速温度值

*LL to decimal -40 represents the temperature value of the set start temperature L
HH is replaced by Decimal -40, which indicates the full speed temperature value of the fan,

*风机的启动、全速温度还可以通过 0x000C、0x000D 分别设置

The starting and full speed temperature of the fan can also be set separately through 0x000C and 0x000D

*特别注意, 风机的全速温度值必须大于启动温度值

Special attention should be paid that the full speed temperature value of the fan must be greater than the starting temperature value



9.4 设置风机数量 (06 功能码, 寄存器地址 0006)

Set the number of fans (06 function code, register address 0006)

指令格式: 调速器地址 06 00 06 00 xx CRC16

Command format: governor address 06 00 06 00 xx CRC16

调速器返回: 调速器地址 06 00 06 00 xx CRC16

Governor return: governor address 06 00 06 00 xx CRC16

*XX 换成十进制就是接入风机的个数, 取值范围 00-04

* XX to decimal is the number of access fans, take the value range of 00-04

9.5 查询风机故障信息 (03 功能码, 寄存器地址 000E)

Read the fan fault information (03 function code, register address 000E)

指令格式: 调速器地址 03 00 0E 00 01 CRC16

Command format: Governor address 03 00 0E 00 01 CRC16

调速器返回: 调速器地址 03 02 00 XX CRC16

Governor return: governor address 02 00 XX CRC16

XX 换算成二进制码, 低 4 位就对应 4 个风扇,

XX is converted into binary code, and the lower 4 bits correspond to 4 fans,

从右往左, 最右位对应 1 号风扇, 第 4 位对应 4 号风扇,

From right to left, the rightmost position corresponds to fan 1, and the fourth position corresponds to fan 4;

0 表示风扇故障, 1 表示风扇正常,

0 indicates the fan fault, and 1 means that the fan is normal

以 modbus 地址 01, 风机数量为 4; 3 号风机故障、124 号风机正常运转 为例,

With modbus address 01, the number of fans is 4, Taking the mal function of fan No. 3 and the normal operation of fan 1 2 4 as an example,

主机发送: 01 03 00 0E 00 01 E5 C9

Host Send: 01 03 00 0E 00 01 E5 C9

调速器应答: 01 03 02 00 FB F9 C7 (0B=11111011, 也就对应出 3 号风机处于故障状态)

Governor return: 01 03 02 00 FB F9 C7 (0B=11111011, means that fan No. 3 is fault)

*此功能码查询出的信息为调速器根据相关配置实际判断出的风机故障状态,

* The information of this function code is the fan fault state determined by the governor according to the relevant configuration,

*此功能必须要配合“风机数量”参数及按要求接入风机才能正常使用

* This function must be combined with the "fan number" parameter and the required

**9.6.1 串口强制控制调速器输出占空比（温控失效）（06 功能码，寄存器地址 0003）**

Serial port force control governor output duty cycle (temperature control failure)
(06 function code, register address 0003)

指令格式: 调速器地址 06 00 03 00 xx CRC16

Command format: governor address 06 00 03 00 xx CRC16

调速器返回: 调速器地址 06 00 03 00 xx CRC16

Governor return: governor address 06 00 03 00 xx CRC16

*XX 换成十进制就是风机转速百分比，取值范围 0x00-0x64

* XX to decimal system is the fan speed percentage, the value range is 0x00-0x64

9.6.2 退出串口控制模式（温控起效）

Exit the serial control mode (temperature control)

指令格式: 调速器地址 06 00 03 FF FF CRC16

Command format: governor address 06 00 03 FF FF CRC16

调速器返回: 调速器地址 06 00 03 FF FF CRC16

Governor return: governor address 06 00 03 FF FF CRC16

9.7 查询 2 号风机转速（03 功能码，寄存器地址 0008）

Read NO.2 fan speed (03 function code, register address 0008)

指令格式: 调速器地址 03 00 08 00 01 CRC16

Command format: governor address 03 00 08 00 01 CRC16

调速器返回: 调速器地址 03 02 xx xx CRC16

Governor return: governor address 03 02 xx xx CRC16

*xxxx 换算成十进制就是 2 号风机的实际转速，单位 RPM(转/分钟)

* xxxx Conversion to decimal is the actual speed of no. 2 fan, unit RPM (rpm / min)

9.8 读取全部参数（03 功能码，寄存器地址 0000-000E）

Read all parameters (03 function code, register address 0000-000E)

指令格式: 01 03 00 00 00 0F 05 CE

Command format: 01 03 00 00 00 0F 05 CE

(0000: 寄存器起始地址, 000F: 读取 15 个寄存器)

(0000: Register starting address, 000F: Read 15 registers)

调速器返回: 01 03 1E 00 32 00 01 00 01 00 14 46 5A 00 01 00 04 02 76 00 00 00 00
00 00 00 05 00 46 00 5A 00 FF ED 1E

Governor return: 01 03 1E 00 32 00 01 00 01 00 14 46 5A 00 01 00 04 02 76 00 00 00
00 00 00 00 05 00 46 00 5A 00 FF ED 1E

1E: 返回数据长度，共 30 个字节(15 个寄存器，每个寄存器的数据占 2 个字节)

1E: Return data length, 30 bytes (15 registers, each for 2 bytes)

0032 对应寄存器 0000 的值, 0001 对应寄存器 0001 的值, 依次对应, 以此类推...

0032 corresponds to value of register 0000, 0001 corresponds to value of register 0001, and so on...



我司可免费提供配套的调试软件，界面如下，用户可访问我司官网下载或联系客服提供
Our company can provide supporting debugging software for free, the interface is as follows, users can visit our official website to download or contact customer service to provide



I 订货（版本）信息：

Ordering (Version) information:

JFP4816-J	基础款标配：带显示器，不带 RS485 串口 Basic version standard configuration: with display, no RS485
JFP4816-JL	基础款经济版：不带显示器，不带 RS485 串口 Basic version economy version: no display and RS485
JPF4816-G	高级款标配：带显示器，带 RS485 串口 Advanced version standard configuration: with display and RS485
JPF4816-GL	高级款经济版：不带显示器，带 RS485 串口 Advanced Economy Edition: no display, with RS485



成都兢志成电子科技有限公司

Chengdu Jingcheng Electronic Technology Co., LTD

官网/website: www.jzcet.com

固话/Fixed-line: 028-66570969

手机/Mobile phone: 18227618314

邮箱/Email address: jzcet@foxmail.com

地址/Address: 四川省成都市双流区龙桥路 6 号

Address: No.6, Longqiao Road, Shuangliu District, Chengdu, Sichuan